



Technical Regulations

Formula Ford

With 1600cc Kent Engine

Issue 2:- March 2004

Technical Regulations for Formula Ford 1600

Introduction

The first race for Formula Ford cars was held on July 2nd 1967, using the 1498cc engine from the Cortina and ordinary road-going Firestone F100 tyres. Changes had to be made over the years to keep both the engine in line with current production, firstly to 1600cc and later to the cross flow engine, whilst also improving the tyre specification.

None of these have changed the basic concept of the Formula.

No changes have been introduced to the current cars, except for the safety requirement of Lateral protection structures on 1996 and later cars only.

The current cross flow, 1600cc, "Kent" engine is no longer in production and we are pleased that the formula is still thriving and wish it many more years of success.

The "Kent" engined formula now has its own regulations and they are no longer combined with the regulations for the 1800cc "Zetec" engined cars.

Copies of the regulations and other information can be obtained from

Regulations On the Web at
www.formulaford.info
or
John Griffiths
Ford Motor Company Limited
Dunton Technical Centre
Room GB - 15/GA - Y02 - E
Laindon
Essex SS15 6EE

Tel: 01268 403101
jgriffit@ford.com

Parts Ford Dealerships, or Formula Ford
International at
Phone; 0044 (0)1442 220200
Fax 0044 (0)1442 220347
Att: Don Hilton (07889 607998 mobile)

Warning

The following regulations have not been updated for several years. Irrespective of these regulations ALL cars must comply with at least the current minimum safety standards specified in the country of the competition. (Safety Helmets, Safety Belts, Fire Extinguishers etc.)

For Standard Ford Motor Company parts that are specified in these regulations, and are no longer available from any source, the competitor must obtain the written consent from the Scrutineer responsible for that race meeting or championship prior to using the alternative part in competition. (July 2001)

Copyright

Copyright for the regulations are not retained by Ford Motor Company Limited if these regulations are copied in total. Any changes made to the regulations are not permitted unless sanctioned by the Ford Motor Company Limited.

Technical Regulations

Formula Ford 1600

GENERAL

As with all regulations, "UNLESS IT SAYS YOU CAN DO IT. YOU CANNOT".

1 DESCRIPTION

Four wheel, single seater racing car, as defined for Formula 3 (1985) and these regulations fitted with a Ford 1600cc GT "Kent" Engine.

2 SAFETY

These regulations are based on the current RACMSA Yearbook (Blue Book). All relevant end current RACMSA regulations apply. See Appendix 'A' for some of the more specific regulations.

3 CHASSIS

The chassis must be of tubular steel construction with no stress bearing panels except bulkhead and undertray, curvature of the undertray must not exceed 2.54cm. The undertray/floor (E 13.2.4) extends from the bulkhead forward of the pedals to the bulkhead between the fuel tank and the engine. Monocoque chassis construction is prohibited. Stress bearing panels are defined as, sheet metal affixed to the frame by welding or bonding or by rivets, bolts or screws which have centres closer than 15.25cm. Bodywork must not be used as stress bearing panels. The use of stabilised materials, composite materials using carbon and/or Kevlar reinforcement is prohibited.

3.2 Cars built after 1.1.87 and before 1.1.95 The internal cross section area of the cockpit from the driver's feet to behind his seat, shall nowhere be less than 700 cm² and a minimum width must be 25cm over the whole length of the cockpit. The only intrusion permitted into the cross sectional area being the steering column.

3.3 Cars built after 1.1.95 The free internal cross section of the cockpit from the soles of the driver's feet to behind his seat shall at no point be less than 700cm². The only thing which may encroach on this area is the steering column. A free vertical section of minimum 25cm width maintained to a minimum height of 25cm with corners of maximum 5cm radius must be maintained over the whole length of the cockpit

with the steering wheel removed. The driver normally seated in his driving position with the seat belts fastened and the steering wheel in place must be able to raise both legs together such that his knees reach the plane of the steering wheel in the rearwards direction: this action must not be obstructed by any part of the car.

3.4 Cars built after 1.1.87 The soles of the feet of the driver, seated in the normal driving position and with his feet on the pedals in the inoperative position, shall not be situated to the fore of the vertical plane passing through the centre line of the front wheels.

3.5 No engine oil or water tubes are permitted within the cockpit

3.6 Cars built after 1.1.95 The chassis must include an impact-absorbing structure fitted ahead of the front bulkhead of the tubular steel frame. This structure must be independent of the bodywork and must be solidly fixed to the extremities of the bulkhead (i.e. with bolts requiring tools for removal). It must constitute a box of 30cm minimum length, 15cm minimum height in any vertical section and 400cm² minimum total cross section. It must be metallic using honeycomb sandwich construction with a panel thickness of 15mm minimum. It is recommended, but not mandatory, that this safety feature is fitted to older cars.

3.7 Cars built after 1.1.96 must be built with a LATERAL PROTECTION STRUCTURE, defined as continuous panels whose projection on a vertical plane parallel to the longitudinal axis of the car shall be at least 15cm high, shall extend on either side of the car, at a minimum distance of 55cm from the car's longitudinal centre line between at least the transverse planes passing through the fuel tank rear face and the frontal extremity of the minimum cockpit opening, and at a minimum distance of 35cm from the car's longitudinal centre line between at least the transversal planes passing through the above extremity and the front rollover bar hoop. These panels shall be made from a composite material of 30cm² minimum cross section with a honeycomb core in metal giving adequate resistance to compression. The external skins shall be of aluminium alloy of a minimum thickness of 0.5mm or made up of another assembly of materials of equivalent efficiency. The panels must be securely attached to the bottom and at the upper extremity to the main structure of the car in such a manner as to ensure absorption of a lateral impact. The radiators may play the role of protective panels

or of transversal struts. The periphery of the bodywork covering the Lateral Protection Structure, when viewed from below, must be curved upwards with a minimum radius of 5cm, and a maximum radius of 7cm with the exception of air entry and exit openings into the Lateral Protection Structure. The floor of the side pod must reflect the plan of the upper surface. The floor is to be in the same plane as the undertray in both directions, i.e. transverse and longitudinal, subject to all points being within 2.54cm of any flat plane situated under the car (see Art 3.1).

4 BODYWORK

See table of single seater dimensions. (Appendix "B"). The use of composite materials using carbon and/or Kevlar reinforcement is prohibited. Bodywork is not required behind the vertical plane taken through the front of the topmost portion of the roll over structure. If bodywork is used it must conform with the following regulation.

- 4.1 Any device designed to augment aerodynamically the downthrust on the vehicle is prohibited, as are aerofoils, nose fins or spoilers of any type.
- 4.2 For cars built after 1.1.87 The engine cover must not extend rearwards past the rearmost point of the gearbox housing (no gearbox extensions permitted). The shape of the cover must not include any reflex curves and no flat surfaces are permitted within 15° of the horizontal
- 4.3 For cars built after 1.1.87 The lower rear bodywork (located below the wheel centre line) is only permitted alongside and beneath the engine and can only extend from behind the cockpit to a line drawn through the rear axis. The incorporation of suspension or other fairings in this bodywork or separately is prohibited.
- 4.4 It is not permitted to construct any suspension member in the form of an aerofoil or to incorporate a spoiler in the construction of any suspension member
- 4.5 All cars must have at least two mirrors mounted so that the driver has visibility on both sides of the car (minimum surface area of each one: 55cm².)
- 4.6 For cars built after 1.1.95 Cockpit opening: The opening giving access to the cockpit must allow a designated horizontal template to be inserted vertically into the cockpit (not considering the steering wheel) down to 25mm lower than the lowest point of the cockpit

opening. This template is defined by dimensions J,K,L in Appendix "B".

4.7 See also Lateral Protection Structures.

5 ENGINE

5.1 GENERAL

- a) Engines will be mounted upright, and aligned fore and aft in the chassis.
- b) The addition of any material be it metal, plastic or composite etc. by any means be it welding, bonding, encapsulation or encasement to any component is prohibited. However, specific repair of the mounting points of the cylinder block to the transmission or chassis are allowed, whilst other casting repairs may be allowed with prior written approval of the Technical Commissioner responsible for the Formula.
- c) Balancing of reciprocating and rotating parts is permitted only by removal of metal from locations so provided by the manufacturer.
- d) Pump, fan and generator drive pulleys and their retention bolts, washers and belts are free.
- e) Mechanical tachometer drives may be fitted.
- f) Generators are optional.
- g) The use of non-standard replacement fasteners, nuts, bolts, screws, studs and washers which are not connected with, or which do not support, any moving parts of the engine or its compulsorily retained accessories is permitted. Freedom granted to any fastener does not allow for freedom to move items relative to each other. For components that are granted the freedom for the fitment of a key or dowel, then material may be removed to allow the fitting of the key or dowel. Only one hole or keyway per component is allowed.
- h) The use of thread locking compounds is permitted.
- i) Gaskets are free except for the cylinder head, intake and exhaust system gaskets which must be standard Ford manufacture for the engine, and inlet manifold to cylinder head gasket which must be of approximate production thickness (see 5.2e).
- j) Any process of cleaning may be used on any component providing the surface finish, which must remain standard, is not affected.
- k) Forced induction is prohibited. Ram Air generated by the forward motion of the car is not considered as forced induction.
- l) The exterior surfaces only (of the complete engine assembly) of ferrous parts and the exterior surface of the aluminium Rocker Cover may be protected by paint or similar means. No internal component or surface may be coated by any protective finish. Other Ford produced aluminium components may be protected only

on their external surfaces by a transparent clear varnish, or similar.

m) Part numbers quoted were correct at the time the regulations were drafted. However, as with all companies, the Ford Motor Company Limited reserve the right to make changes to components for reliability or other reasons. Consequently the part numbers quoted may be superseded by later released parts. Full Ford part numbers do not necessarily appear on all parts.

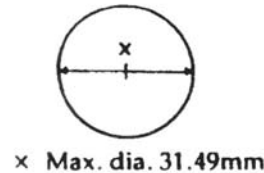
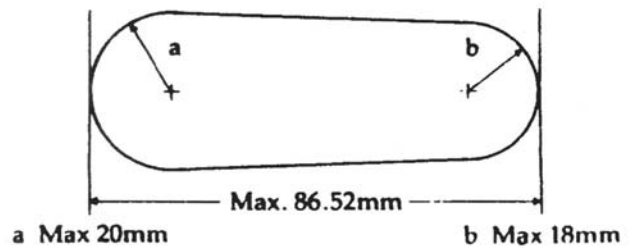

Manifold port diameter may be exceeded in vertical plane if casting is original and untouched

5.2 PERMITTED ENGINE

The only permitted engine is the Ford 1600 GT "Kent" (also referred to as Mark II Escort 1600 "Sport") with a nominal bore 81 mm and stroke 77.6mm. Production tolerances are permitted providing the total swept volume does not exceed 1600cc.

5.3 INDUCTION

a) The air cleaner may be removed or replaced and a trumpet fitted.
b) Carburettor Type: Weber 32/36 DGV and DGAV (from 1600 GT "Kent" or 2000 SOHC NE engine).

Number on engine	1
Number of Main Venturi	2
Maximum dia. of Main Venturi	26.0/27.0mm
Maximum dia. of carb outlet to inlet manifold	32.0/36.0mm

c) It is permitted to change jets, open both throttles together, remove cold start devices and diffuser bar, fit internal and external anti-surge pipes, remove seals on emission control carburettors. No other modifications are permitted, chokes must remain standard and no polishing or reprofiling is permitted. Any means of reducing intake air temperature is prohibited. Any form of water injection is prohibited.

d) Inlet manifold: standard Ford production inlet manifold for 1600 GT "Kent" engine. The carburettor seat face may be machined to horizontal in the fore and aft plane. The water passage must remain intact but may be blanked off or plugged. The manifold may be machined externally to clear the throttle mechanism in the use of both throttles being opened together.

e) Carburettor to inlet manifold gasket Thickness 5.7mm \pm 0.35mm Inlet manifold to cylinder head Thickness 0.86mm (max)

5.4 EXHAUST SYSTEM

a) The exhaust system and manifold are free, within Vehicle Regulations.
b) A mandatory silencer, Ford Part No. 9095317 (or old unit 9094277) must be fitted

5.5 CYLINDER BLOCK

a) It is permitted, as means of repair, to replace damaged cylinder bores with cast iron cylinder liners, all to standard dimensions.
b) Localised machining of the cylinder block is permitted to allow fitting of the dry sump system.
c) The crankcase breather may be altered or removed, but all breathers must discharge into a catch tank.
d) May be machined to maintain deck height.

5.6 CYLINDER HEAD (INCLUDING VALVES AND VALVE GEAR)

a) Non-standard rocker covers are permitted providing they in no way improve the performance of the engine. Water passages are not permitted in rocker covers.
b) Standard valve spring retainers must be used, only single valve springs are permitted. Shims are permitted, otherwise valve springs are free.
c) Push-rods, rockers, tappets, pedestals and shafts must remain standard except that recontouring of the valve stem contact pad on the rocker arm is permitted providing the maximum specified lift at the spring cap is not exceeded. Rocker shaft springs are free.
d) Maximum permitted lift at the spring cap with zero tappet clearance:
inlet 9.042mm, exhaust 9.093mm.
Maximum permitted lift at the top of the push rod:
inlet 5.917mm, exhaust 5.943mm.
e) Valves must remain standard, no reprofiling or polishing is permitted. The original 45° seat angle must be maintained.

Distance apart at centres $39.12 \pm 0.5\text{mm}$.
 Maximum face diameter, inlet 39.62mm ;
 exhaust 34.00mm .
 Overall length inlet $110.92 \pm 0.5\text{mm}$.
 Overall length exhaust $110.61 \pm 0.5\text{mm}$.

Valve stem seals are optional.

f) It is permissible to reshape inlet and exhaust ports by removal of metal within limits. Addition of material in any form is prohibited.

Maximum port diameter at manifold face:
 inlet 36.12mm , exhaust 29.41mm .

Inlet and exhaust port diameter may be exceeded if the original casting is visible and untouched at the gasket face.

g) It is permitted, as means of repair, to replace damaged valve guides and valve seats by replacement valve guides and valve seat inserts, all to standard dimensions

Dimension	Symmetrical	
	Inlet	Exhaust
DM (max)	33.60mm	33.65mm
Dm	27.78mm	28.15mm
Lift at 0°	5.37mm	5.89mm
Lift at 5°	5.81mm	5.85mm
Lift at 10°	5.64mm	5.67mm
Lift at 15°	5.38mm	5.41mm
Lift at 20°	5.00mm	5.03mm
Lift at 30°	4.01mm	4.04mm
Lift at 40°	2.69mm	2.77mm
Lift at 60°	0.46mm	0.61mm
Lift at 90°	0.05mm	0.20mm

5.7 COMPRESSION RATIO

a) The maximum compression ratio will be controlled as follows:

i) Minimum combustion volume in piston 41cc (with piston at TDC in cylinder and no account taken of volume down from the crown to the top piston ring).

ii) Standard Ford cylinder head gasket Part No. 781M 6051 AA / 931M 6051 AA minimum compressed thickness 0.85mm, minimum diameter of cylinder head aperture 82.50mm.

iii) Pistons must not protrude above the cylinder block face at TDC. The cylinder block surface may be machined.

iv) Maximum permitted protrusion of the valves into the combustion chamber 1.2mm.

5.8 CAMSHAFT

a) The only permitted camshaft is the Ford production camshaft for the 1600 GT "Kent" engine.

b) The camshaft must remain entirely unmodified. It must be fully manufactured and ground to the Ford Motor Company profile. It is prohibited to grind from blanks, regrind or reprofile. Tuftriding or Parkerising is permitted. Shot peening, shot blasting or polishing are prohibited. Offset dowels are permitted.

c) The cam profile is defined by determination of lift (L-l) against a flat footed follower at various angles (θ). Maximum lift at all points on the camshaft must not be exceeded.

Standard Ford tolerances apply to the following camshaft drawing.

Angle between major axes of inlet and exhaust cams: 109° .

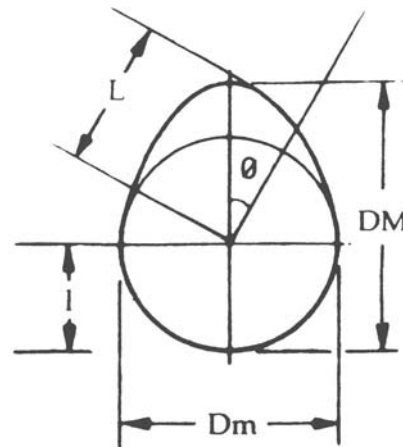

5.9 PISTONS

a) Pistons must be standard Ford production pistons for the 1600cc engine, unmodified in any way except for balancing and as detailed.

b) All three piston rings must be fitted, piston rings must be standard production or similar replacements, i.e. the compression rings must be one piece, with conventional plain gaps, chromium plating of the top ring is optional, the oil control rings must be either single piece twin land type or apex three piece (two rails and an expander). Molybdenum faced top compression rings are permitted.

c) Localised machining of the bowl including valve relief and gudgeon pin bosses of the piston to achieve volumetric and weight balance and minimum weight is permitted. Minimum weight complete with piston rings and gudgeon pin: 520gm, weight of gudgeon pin: $115 \pm 2.0\text{gm}$.

5.10 CONNECTING RODS

a) Connecting rods must be standard Ford Part No. 2737E 6200 B. Machining is permitted to remove metal from the balancing bosses on the big-end cap and at the little end to achieve

balance only. Polishing is prohibited. Minimum weight (including bolts and small end bearing) 640gm.

5.11 CRANKSHAFT

- a) A standard crankshaft must be used. Spot machining to achieve balance is permitted. Tuffriding, shot peening and shot blasting are permitted. Polishing is prohibited. Crankshaft minimum weight: 11.2kg.
- b) Crankshaft pulley is free as is tooth belt drive.
- c) It is not permitted to alter the number of bearings or fit bearings of less than standard production width.
- d) Standard oversize and undersize bearings are permitted.
- e) The rear main journal may be fillet rolled in the radius

5.12 FLYWHEEL AND CLUTCH

- a) The flywheel and clutch assembly must be standard components. To achieve minimum weight and balance, material may be removed from the originally machined surfaces, rim/flange etc. For rectification, the clutch mating face may be resurfaced. Cast surfaces must remain in original condition. It is permitted to use a similar pattern replacement clutch (i.e. conventional single diaphragm spring) driven plate with shock absorber springs. Organic friction material only is permitted. Racing clutches are prohibited.
- b) Flywheel bolts are free and locating dowels are permitted.
- c) It is permitted to secure the starter ring to the flywheel.
- d) Flywheel and clutch assembly minimum permitted weight: 13.16kg. (including all flywheel and crankshaft mounting bolts).

5.13 LUBRICATION SYSTEMS

The lubrication system, external to the engine, is free. Existing standard production oilways, linings or oil grooves may be enlarged or reduced, but no additional ones are permitted. Standard friction surfaces must remain unchanged. Dry sump is permitted, oil coolers are free.

5.14 COOLING SYSTEM

- a) A liquid cooling system is mandatory but radiator and water pump are free.
- b) The radiator, if housed in or incorporating a cool air scoop or deflector, must comply with bodywork regulations.

5.15 FUEL PUMP

- a) Only the standard mechanical fuel pump for the engine is permitted.
- b) Fuel pipes are free. Fuel cooling radiators are permitted, within safety regulations, but

must be mounted within the main chassis frame

5.16 DISTRIBUTOR

- a) Distributors are free providing they retain the original drive and location.
- b) The distributor is defined as the component which triggers the LT current and distributes the HT ignition current. The ignition timing may only be varied by vacuum and/or mechanical means. It is prohibited to use any other method or component to trigger, distribute or time the ignition.
- c) It is permitted to mount a simple indicating pointer to the engine to facilitate the timing of the distributor with respect to the crankshaft/flywheel.

6. SUSPENSION

- a) The following parts must be of alloy steel or other ferrous material: wishbones, rockers, push and/or pull rods. All other stress bearing components must be metallic with no composite materials allowed. It is permitted to incorporate suspension mounting points on the engine and transmission assembly.
- b) Active suspensions are prohibited, as is any system which allows control of the flexibility of the suspension springs, shock absorption and trim height when the car is moving.
- c) Anti-roll bars for front and/or rear suspension may be capable of manual adjustment by the driver when seated in the car.
- d) Simple ovalised tubes which have the same section top and bottom are not considered to be an aerofoil.

7 BRAKES

Only brake discs made predominantly from Ferrous material are permitted. Calipers must be of Ferrous material with a maximum of two working cylinders per caliper. Brake pad materials, including carbon metallic, are free.

8 SHOCK ABSORBERS

Light alloy casings and/or separate reservoirs for fluid/gas are prohibited, otherwise free. Any form of active damping is prohibited. Any method of altering the damper performance by the driver whilst seated in the car is prohibited. The shock absorber casing is defined as the item which contains the piston, fluid/gas, and moving parts which control the damping action.

9 STEERING

The steering must consist of a mechanical link between the driver and the wheels, rear wheel steering prohibited, otherwise free.

10 WHEELS & TYRES

- a) 13 inch diameter steel wheels with a maximum rim width of 5.5 inch are the only

wheels permitted. They must be of standard manufacture but the off-set may be altered. (It is recommended that weekly checks for cracks be carried out and that the wheels be replaced twice a year).

b) The only tyres permitted are those listed in the Sporting Regulations for the event. Minimum tread depth 1mm at the start of each practice session and race.

c) Tyre warmers are not permitted. Tyre covers whose only function is to protect the tyre in the paddock area are allowed. Tyre warmers found at the circuit will be judged to be available for use.

11 TRANSMISSION

a) The gearbox must contain not more than four forward gears and include an operable reverse gear, capable of being engaged by the driver whilst normally seated. The ratios are free.

b) Rear wheel drive only is permitted.

c) Final drive ratio is free.

d) Torque biasing, limited slip and locked differentials are prohibited. Non-ferrous differential components prohibited.

e) Gear change must be manual in operation. The gearchange must use the conventional 'H' pattern gearchange gate. Any gear change mechanism that only allows sequential selection of gears is not permitted.

f) The only position for the main gear cluster will be wholly behind the rear axle output shaft centre line, and in line with the crankshaft centre line. Transverse, vertical, or other non in-line configuration will not be allowed.

12 FUEL SYSTEM

a) Tanks outside the chassis frame must comply with FIA Spec FT3.

b) Inboard tanks, covered externally with a fireproof coating, are acceptable for events of less than 70km.

c) Protection must at all times comply with J20.1.1 and E 13.2.3 (Bulkheads). A metal tank coated with GRP does not comply.

d) Maximum capacity 41 litres unless carried in FIA spec FT3 tank or better.

e) No fuel can be used which exceeds BS 7800: 1992 (Super Unleaded), or BS 4040 (Premium Leaded) or equivalents outside the UK. A mixture of fuels is not allowed. Event regulations are allowed to specify a single source fuel which meets these minimum standards, but do not exceed it.

f) At the end of practice and the race at least 3 litres of fuel from the tank of the competing car must be available to the scrutineers for analysis. Compliance with minimum weight for the car will be taken before the fuel is removed.

13 STARTING

a) Compulsory electric starter with electrical source of energy carried on board the car, and able to be controlled by the driver when normally in his seat.

b) A supplementary external source of energy temporarily connected to the car may be used to start the engine whilst in the pit area.

14 WEIGHT

Minimum car weight at any time during the competition 420Kg

15 ENGINE SEALING

All engines should have provision for scrutineer's wire seals. 1/16 inch dia. holes pre-drilled in readily accessible locations on installed engines must be available. Failure to comply renders the entrant liable to a fine.

a) Sump - two holes through the cylinder block/ sump joint flange, one either side of the engine.

b) Timing Cover - at least two retaining screw heads must be cross drilled.

c) Rocker Cover - at least two retaining screw heads must be cross drilled.

d) Inlet Manifold - at least two retaining bolt heads to the cylinder head must be cross drilled.

e) Carburettor - at least two retaining nuts to the cylinder head must be cross drilled.

f) Bellhousing - at least two retaining bolts to the engine must be cross drilled to enable clutch and flywheel to be adequately sealed, OR competitors must be prepared to remove either engine or transmission to enable sealing of clutch and flywheel in which case at least two clutch cover retaining bolts must be cross drilled. Failure to comply renders the engine ineligible.

16 MISCELLANEOUS

a) Use of titanium, high strength composites, and similar materials is prohibited.

b) Electronic dashboards and Data logging equipment are allowed subject to them having no influence whatsoever on the behaviour of the car during competition. All information obtained from any Data logging or storage equipment shall be made freely available to the Scrutineer on request.

c) Competitors are reminded that only modifications or additions specifically covered by these regulations are permitted. Engine components not covered by these regulations must remain completely standard and unmodified. In cases of dispute on engines, reference will be made to Ford Motor Company Limited drawings.

d) Vehicles defined in these regulations are required to comply with the section of the RAC MSA yearbook covering General Vehicle and

Race Vehicle which apply to single seater racing cars, a summary of which is given in Appendix

PRE-1974 FORMULA FORD 1600

- 1 DESCRIPTION
Single seater racing cars complying with current Formula Ford 1600 regulations, and these regulations, manufactured prior to 1st January 1974.
- 2 CHASSIS
The chassis specification must remain fundamentally unaltered from original manufacture. Wheelbase, Track, and pick-up points must remain to manufacturers specification.
- 3 PERMITTED MODIFICATIONS
To current Formula Ford-1600 regulations.
 - 3.1 Any modification of which the primary purpose is safety or driver comfort.
 - 3.2 Bodywork is free within FF-1600 dimensions.
 - 3.3 Coil springs, shock absorbers, anti-roll bars and steering rack are free providing they fit to the same original locations.
 - 3.4 Wheel off-sets may be varied to alter track dimensions by a maximum of 3 inch.
 - 3.5 All transmissions in production before 1st January 1974 in FF are permitted.
 - 3.6 Make and type of drive shaft is free.
 - 3.7 The number, type and location of radiators is free.
- 4 Miscellaneous
 - 4.1 Cars may be updated to the specification of the latest model built by the manufacturer which appears in the list of eligible vehicles (e.g. Merlyn Mk1 1A up to Mk24 specification).
- 4.2 **ELIGIBLE CARS** if built prior to 1st. January 1974
 - Alexis Mk 1 4B to 24B
 - Cougar
 - Crossle 1 6F & 20F
 - DRW Mk8
 - Dulon LD4, LD4A to LD4C, LD9, MP15 & MP1 5B
 - Eldon Mk8, Mk10 to 1 0C
 - Ginetta G18, G1 8B
 - Hamlen FF69
 - Hawke DL2A, DL2B, DL9, DL10, DL11
 - Huron FF
 - Image FF1
 - Jamun T2, T3
 - Jomic Mk2A
 - Jomo
 - Lola Mk5A, T200, T202, T204
 - Lotus 51, 61, 61M, 61R, 61X, 69
 - Macon
 - Matek
 - McNamara
 - Merlyn Mk9, Mk11A, Mk17, Mk17A, Mk20A, Mk24

Mirage M5
Mistrale
MRE FF72, FF73
U2 Mk9
Nike Mk10B (prior to 1.1.74)
Nomad KH/FF16
Norvic
Oscar
Palliser WDF1, WDF2, WDF3
Ray 71, 72, 73
Rostron CT2, CT3, CT4
Royale RP3, RP16, RP1 6A
Titan Mk4, Mk5, Mk6A to 6C
Van Diemen RF73

Specials

Brabham BT21 /28
Chevron B1 5/17
March 718/2
Varo (Lotus 22 derivative)

APPENDIX "A"

GENERAL REGULATIONS

Excerpts from RAC MSA Yearbook.

- E13 All cars must comply with the following regulations which are reprinted from the general vehicle and all vehicle race section of the RAC MSA Yearbook. The following are for your guidance and do not claim to cover all RAC MSA requirements.
- E13.1 As a general principle in all Technical Regulations, it is prohibited to carry out any tuning or modification that is not specifically permitted. The fact that some modifications are mentioned as prohibited does not imply that others are allowed.

ALL VEHICLES MUST:

- E13.2.1 Be fitted with BODYWORK with a driver's compartment isolated from the engine, wet batteries, gearbox, transmission shafts, brakes, road wheels, their operating linkages and attachments, petrol tanks, oil tanks, water header tank and catch tanks.
- E13.2.3 Have a PROTECTIVE BULKHEAD of non-inflammable material between the engine and the driver's compartment capable of preventing the passage of fluid or flame. Gaps must be sealed with GRP or

- Intumescent Putty. MAGNESIUM is prohibited for bulkheads.
- E13.2.4 Have a complete FLOOR of adequate strength rigidly supported within the driver compartment.
- E13.3.2 If a single seater, the maximum time for a driver to get in or out of the vehicle must not exceed 5 seconds.
- E13.5 Suspension: Be fitted with SPRUNG SUSPENSION between the wheels and the chassis. Suspension must be controlled to avoid fouling of wheels on chassis or bodywork.
- E13.6 Brakes: Be fitted with brakes that are operative and capable of stopping the vehicle as required.
- E13.7.1 Steering: Have a STEERING WHEEL with a rim of minimum continuous arc of 180°.
- E13.7.2 Have STEERING MOVEMENT controlled to avoid fouling of wheels on chassis or bodywork.
- E13.8 WHEELS
a) Have not less than FOUR ROAD WHEELS and tyres (excluding the spare).
b) Not be fitted with any WHEEL SPACER exceeding 2.5cm in thickness or of less than hub diameter. Multiple or laminated spacers prohibited.
c) Have all HUB NAVE PLATES and WHEEL EMBELLISHERS removed
- E13.13.3 Use PUMP FUEL (see definition).
- E13.14.1 Electrical Systems: Have any wet BATTERIES in driver's compartment enclosed in a securely located leak-proof container.
- E13.14.2 Have BATTERIES duly protected to exclude leakage of acid and to protect terminals from short circuiting and producing sparks.
- E13.14.5 Have the BATTERY EARTH LEAD, if not readily distinguishable, identified by a yellow marking. E13.14.6. If required to have a SELF-STARTER, be able to demonstrate during the competition that it is capable of starting the engine.
- E13.14.7 Be fitted with SUPPRESSORS as required by the Wireless Telegraphy Regulations.
- E15.5 WEIGHT/BALLAST: If subject to a MINIMUM WEIGHT that must be the weight of the vehicle in the condition in which it crosses the finishing line (excluding driver), or at any time during the competition and/or practice.
- E13.16.4 Not have EXHAUST PIPES extending more than 60cm beyond the rear wheel axis.
- E13.17 Silencing: The reason for Silencing (Noise Control) is not to inconvenience competitors, it is to reduce inconvenience to others and keep motorsport running. Noise and the Control of Pollution Acts have far reaching implications and sources of complaint can be subject to immediate suppression by Environmental Health Authorities. Motorsport Noise is not welcomed by many people and is often classified as unsociable. Our system of control is acceptable to most Environmental Bodies and must be considered as part of Eligibility to Compete in events
- E13.17.5 If specific technical regulations specify a MANDATORY SILENCER it must be used irrespective of the EXHAUST NOISE generated without it.
- E13.19 MISCELLANEOUS
- E13.19.1 Be of SOUND CONSTRUCTION and MECHANICAL CONDITION and be well maintained
- E13.19.2 Have positive FASTENINGS for all hinged or detachable parts of the bodywork.
- E13.19.3 Have no TEMPORARY PARTS incorporated in their construction. E13.19.5 Be prohibited from carrying CAMERAS unless authorised by the Chief Scrutineer and Event Organiser.
- E13.19.9 Not have SKIRTS, bridging devices or any form of aerodynamic device between the chassis and the ground/track. Any specific part of the car influencing its aerodynamic performance must:
i) comply with rules relating to coachwork.
ii) be rigidly secured to the entirely sprung part of the vehicle.
iii) remain immobile in relation to the vehicle.
- E13.19.10 Not carry or pass any liquids in or through any tubes comprising part of the chassis structure, or safety roll-over bar.

J SPECIFIC REGULATIONS FOR RACING

- J20.1.1 Have a BULKHEAD between any fuel tank and filler and the driver's compartment sufficient to prevent the passage of flame or liquid. Where a fuel tank constitutes part of the bulkhead, an additional bulkhead must be fitted. Additional fuel tank protection may be required for open seater cars. (See E13.2.3).

J20.1.2 Not have any SKIRTS or intermediary devices bridging the gap between the underside of the chassis/body of the vehicle and the road/track. Ground clearance to be as per DEFINITION 4cm minimum, unless stated otherwise in the Supplementary regulations.

J20.2.4 Have any UNDERTRAY provided with drainage holes to prevent accumulation of liquids.

J20.4 Engine: Be equipped with a positive method of THROTTLE CLOSING, so that in the event of failure of any part of the Throttle Linkage, the Throttles are automatically sprung closed.

J20.5 Brakes: Be equipped with BRAKES which comply with Statutory Requirements as to the construction of Motor Vehicles, or if there is no mechanical system available for applying braking effort to at least two wheels, there must be two hydraulic systems so that, in event of failure of one system, braking is maintained on at least two wheels.

a) Vehicles must have brakes on all wheels.

b) The braking system on all vehicles must be capable of demonstrating its efficiency without impairing the driver's control when tested immediately prior to an event.

c) It must be possible under all conditions, running or stationary, for 25% minimum braking effort to be applied by the driver through the braking system to each axle.

d) Brake balance adjusters must not be available for adjustment during running if they contravene (c)

J20.7.2 Have all NUTS securing ROAD WHEELS, excepting those of centre-lock type, of steel and in thread contact over a minimum length of 1.5x bolt/stud diameters. Extended or composite wheel bolts/studs are prohibited.

J20.10 FUEL SYSTEM: Be equipped with an effective method of stopping FUEL SUPPLY operable by the driver when normally seated

J20.11.1 ELECTRICAL SYSTEM: Be equipped with an externally operated circuit breaker having positive ON-OFF positions clearly marked (Q8). An internal ignition switch must be operable by the driver when normally seated irrespective of whether a safety harness is worn or not.

J 20.11.2 Not have any ignition components, coils, chokes, black boxes, located in the COCKPIT AREA in racing cars.

J20 14.2 Be fitted with SAFETY HARNESS to be worn at all times by the driver during training practice and competition.

J20.14.5 Not pass fluids through any chassis tubes in space frame vehicles.

J20.15.2 Be presented at Scrutineering with all STEERING MECHANISM, SUSPENSION LINKAGES and FLEXIBLE BRAKE LINES in clean condition.

SAFETY REQUIREMENTS

The following sections of Q Safety Criteria are mandatory.

Q1.4 Exceptions: The only exceptions to the foregoing requirements (Safety Roll Over protection cage) for saloon, single seater and sports cars are as follows:

Q1.4.1 Safety cage manufacturers may submit a safety cage of their own design to the MSA for approval as regards the quality of the steel used, the dimensions of the tubes, the optional reinforcing members and the mounting to the vehicle, provided that the construction is certified to withstand the forces given hereafter in any combination on top of the Safety Cage: 1.5w Lateral 5.5w Fore and aft (w = weight of the car + 75kg) 7.5w Vertical Note: Where a safety cage manufacturer submits a cage and full documentation to the MSA a 'Rollbar' certificate will be raised and issued. Duly authorised copies of this certificate containing a drawing and/or photograph of the safety cage and a declaration that the rollcage can resist the forces specified must be available to event Scrutineers.

Q1.4.2 To obtain MSA approval, a manufacturer **must** have demonstrated his consistent ability to design and manufacture safety cages, which comply with the specifications approved by FIA.

Q1.4.3 Manufacturers recognised by the MSA must only supply customers with products designed and manufactured to the approved standards.

Q1.4.4 Each MSA approved manufacturer must be able to demonstrate to the MSA:

a) That the material used has a certificate of origin or traceability and is kept segregated from other batches of material.

b) That welding procedures he uses produce consistent and sound welds and are regularly checked by laboratory tests.

c) That he operates and maintains auditable in house quality standards and procedures which are updated regularly.

Q1.5.3 Single seater racing cars The rollbar must be symmetrical about the lengthwise centreline of the car and of minimum height 90cm measured vertically from the base of the cockpit or 92cm measured along the line of the driver's spine from the bottom of the car seat. There must be at least one brace rearwards from the top of the rollbar at an angle not exceeding 60° with the horizontal. This brace must be the same diameter as the rollbar. If two braces are fitted to the tube the diameter may be reduced to 20-26mm, the wall thickness being maintained. In addition, forward facing braces should be considered. The width inside the roll-over bar main tubes must be 33cm minimum measured 60cm above the base of the seat. It must incorporate a crossbrace to restrain the driver's head and give rearward support. The top hoop radius must not be less than 10cm measured at the centre line of the tube. **MINIMUM MATERIAL MINIMUM DIMENSIONS** Cold drawn seamless 42.4mm dia x 2.6mm Carbon steel 350N/mm²

Q1.5.5 ALL aluminium alloy roll cages are prohibited.

Q1.6 **AERODYNAMICS**
The use of a rollbar to achieve or supplement aerodynamic effects is prohibited.

Q2.1.3 **SEATBELTS - Six point.**
Two shoulder straps, one abdominal strap and two straps between the legs, with six fixation points on the chassis of the vehicle. One either side of the driver, two to the rear of the driver's seat and two between the legs. The fixation point to the rear should be positioned so that the strap from the shoulder is as near horizontal as possible. It should not be located on the floor directly behind the driver/co-driver. Notes: Seat belts once involved in a serious accident should be discarded. It is not permitted to mix parts of seat belts. Only complete sets as supplied by manufacturers should be used. Only one release mechanism is permitted on each seat belt configuration and this must be available for the wearer to operate whilst seated in the competing position. Belts subjected to oil, acid or heat should be replaced.

Q3 **FIRE EXTINGUISHERS**
A fire extinguisher/extinguishing system should be carried on all vehicles, the minimum requirement being that it should be either BCF, or equivalent extinguishant and be operable by the driver while normally seated either by manual operation or by a mechanically/electrically assisted triggering system.

Q3.1 Extinguishers will be classified as Small, Medium or Large, and designated as Hand Held or Plumbed-in. Due to variations in weight and specific gravity of the different extinguishants, lists of manufacturer's equivalents will be compiled against the previous Halon weights, and will be available from the RACMSA. Dry powder extinguishers are prohibited. Note: As replacement extinguishers become available, "Halon" is being phased out. Every effort should be made to establish the changeover by 1 January 1996.

Q3.1 CAPACITIES

Q3.1.2 (a) Medium, Plumbed-in, for discharge into both cockpit and engine compartment.
(b) Medium, Hand operated, for discharge into both cockpit and engine compartment.

Q3.1.5 Hand operated for cockpit (International).

Table of Equivalents

Size	BCF	NAS S3	NAF P	AFFF	Zero 2000
Q3.1.2 (a)	2.5Kg	2.0Kg	2.0Kg	2.25Kg	2.25Kg
Q3.1.2 (b)	2.5Kg	2.0Kg	2.0Kg	1.75Kg	N/A
Q3.1.5	4.0Kg	3.2Kg	3.2Kg	2.4Kg	N/A

All capacities are minimal
(N.B. Under current legislation, BCF; NAS S"; NAF P can no longer be used)

Q3.2.1 Plumbed in Systems The Large unit should have two points of triggering - one for the driver and one outside the car for activation by marshals etc.

Q3.2.2 The triggering point from the exterior must be positioned close to the circuit breaker (or combined with it) and must be marked by the letter "E" in red inside a white circle of at least 10cm diameter with a red edge.

Q3.2.3 In installing units the direction of nozzles should be carefully considered, induction, exhaust, ignition and fuel pumping systems being the most likely areas for fire to occur.

Q3.2.4 Where possible sources of fire exist outside the engine or cockpit areas advice should be sought from the MSA concerning plumbed-in system installations

Q3.2.5 All bottles should discharge simultaneously and must be operable in any position of the car even if inverted.

- Q3.2.6 It is strongly recommended that plumbed-in bottles should be mounted in the fore and aft direction in the vehicle. The fitting of a pressure gauge is recommended.
- Q3.2.7 Method of Operation: The preferred method of operation is electrical which should have its own source of energy for triggering, ideally with provision for checking the integrity of the system's triggering circuit.
- Q3.2.8 Mechanically operated systems, if used, should be fitted with 'Total Discharge' valves (i.e. ones that continue to discharge even if the operating mechanism should fail after triggering). Hand-held extinguishers which have been adapted, by addition of pull-cables, rarely have the capability of being operated in varying positions and are not acceptable.
- Q3.2.9 Weight checking: Extinguisher systems should be capable of being dismantled for the purpose of checking the weight of the extinguishant and the integrity of the cylinder, also to enable the operating system to be serviced without discharging the contents. The tare weight of the unit must be marked on the cylinder.
- Q3.2.10 Installation: Particular attention should be paid to the installation and maintenance of any system, especially if it is mechanically operated. Pull cables should be fitted in such a way that no kinks or 'S' bends are formed which could cause malfunction
- Q3.3 DURING EVENTS:
- Q3.3.1 All plumbed-in extinguisher systems must be in an 'ARMED' condition (i.e. be capable of being operated without the removal of any safety device) at all times whilst competing or practising.
- Q3.3.2 Any plumbed-in extinguisher system found to be incapable of being operated will be the subject of a report to the Clerk of the Course/Stewards for possible penalisation as an offence against Safety Regulations.
- Q3.3.3 Checking for correctly 'armed' extinguisher systems should only be carried out by MSA Scrutineers, and/or Judges of Fact nominated for that purpose.
- Q4 SAFETY FUEL CELLS
The FIA approved standard for Safety Fuel Cells is FIA Spec. FT3. These fuel cells are only manufactured by authorised companies and bear the name of the company, specification, code and date of manufacture stencilled on each cell. No other cells are approved. Cells of over five years old are deemed obsolete.
- Q5 RED WARNING LIGHT
A rearward facing red warning light of a minimum of 21 watts, with surface area minimum 20cm², maximum 40cm². or of 21 watts with a surface area minimum of 50cm² and with lens and reflector to EC standards, must be located within 10cm of the centre line of the vehicle and be clearly visible from the rear. The warning light must be switched on when visibility conditions are reduced or when instructed by the Clerk of the Course. Alternatively an FIA or Series sanctioned rear warning light may be employed, despite its current consumption being less than 21 Watts, provided the light output equals or exceeds that of the light units defined above.
- Q6 TANK FILLERS, VENTS, AND CAPS
Tank fillers and caps must not protrude beyond the bodywork or be situated within the driver/passenger compartment. The caps must have an efficient locking action to reduce the risk of opening during an accident and ensure closing after refuelling (Q14.1.2). Air vents must be at least 25cm to the rear of the cockpit.
- Q7 CRUSHABLE STRUCTURES
Q7.1.4 All oil tanks mounted outside the main chassis structure must be surrounded by crushable structure of minimum thickness 10mm
- Q8 EXTERNAL CIRCUIT BREAKERS
The circuit breaker, when operated, must isolate all electrical circuits with the exception of those that operate fire extinguishers. On open cars it should be situated on the lower main hoop of the roll-over bar. The location to be identified by a Red Spark on a White-edged Blue triangle, and the 'On' and 'Off' positions clearly marked. Note: When the cut-out is operated, there must be no power source capable of keeping the engine running.
- Q13 HEAD RESTRAINTS
Head restraints must be fitted, capable of restraining a 17kg mass decelerating at 5g. Dimensions to be 10cm x 10cm and located such that the driver's helmet is restrained and cannot move past it under rearward forces, or be trapped between the rollbar and the head restraint. It is recommended that it be within 5cm of the driver's helmet when normally seated.
- Q14 GENERAL SAFETY RECOMMENDATIONS
Q14.1 Owing to the widely varying nature of competitions and vehicles taking part in them,

the MSA takes the view that it would not be in the best interests of the competitors to cover all aspects of safety precautions with mandatory regulations. Inevitably such regulations could not necessarily provide for the most appropriate safety precautions in all foreseeable circumstances. The MSA therefore draws attention to the following points so that the competitors can consider them and take precautions as seem appropriate to their own particular requirements.

Q14.1.1 ELECTRICAL

- a) Batteries - precautions should be taken to reduce the possibility of acid burns from batteries in case of accidents. Batteries should be sealed in a leak-proof, non-conductive, insulated compartment.
- b) Electrical System - all wiring should be secured and well protected to reduce the risk of fire from electrical short circuits.

Q14.1.2 FUEL

- a) Fuel Tanks and Pipes - every effort should be made to isolate fuel tanks and pipes from the driver's compartment. The risk of fuel spillage from accident damage can be reduced by use bag-type tanks or by coating metal tanks with GRP Tanks should be located so that they are given maximum protection by the structure of the vehicle. Vents should be designed to avoid spillage if the vehicle becomes inverted.
- b) Fuel Fillers - these should be designed and located to reduce risk of damage. Filler caps should not be liable to open in the case of an accident. Simple screw caps are effective. The positive locking of the fuel filler caps is recommended. The filler pipe to the tank should be of minimum possible length and not protrude beyond the bodywork (Q6).

- Q14.1.7 Radiator Caps These caps should be positioned or shielded in such a way that hot water or steam cannot scald the driver of the vehicle if they become opened or broken in an accident

APPENDIX "B"

Table of Single Seater dimensions

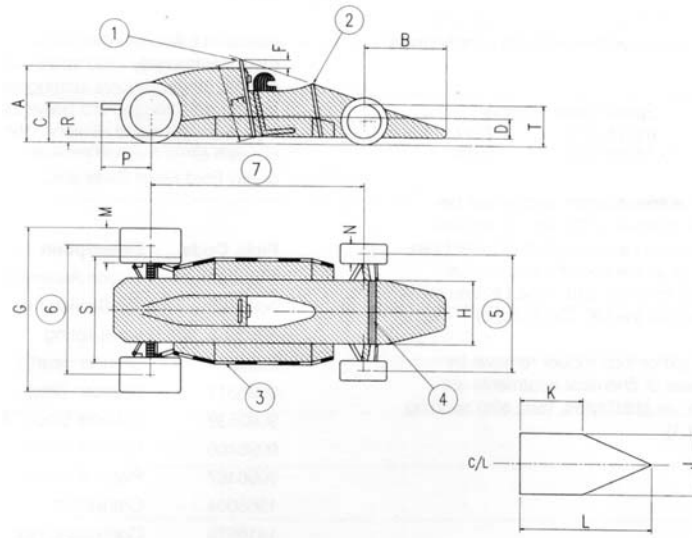

- | | |
|---------------------------------|----------------------------------|
| 1. Safety roll over bar | 2. Substantial support structure |
| 3. Lateral Protection structure | 4. Substantial structure |
| 5. Front track | 6. Rear track |
| 7. Wheelbase. | |

Notes

Maximum height is measured with the driver aboard.

Maximum height excludes safety roll-over bar on which there is no maximum height

Single seater dimensions - refer to drawing

(A) Maximum body height measured from ground	90
(B) Maximum front overhang from front wheel axis	100
(C) Exhaust height measured from the ground	60 Max
(D) Minimum height of Lateral Protection Structure	15
(E) Minimum safety roll-over bar length in line with drivers spine	92
(F) Minimum allowed helmet clearance	5
(G) Maximum width	185
(H) Maximum body width behind front wheels	95
(J) Minimum cockpit opening	45
(K) Minimum cockpit parallel opening length	30
(L) Minimum cockpit overall opening length	60
(M) Maximum rear wheel width	5.5 inch
(N) Maximum front wheel width	5.5 inch
(P) Maximum exhaust length from rear wheel axis	60
(R) Minimum ground clearance	4
(S) Maximum width including lateral protection structure	130
(T) The maximum height of any part wider than 110cm ahead of the front wheels is not to exceed the front rim height	
Minimum wheelbase	200
Minimum track	120
Wheel diameters	13 inch

ALL dimensions in cm unless specifically stated

APPENDIX "C":

TYRES

The only approved tyres (subject to a three year contract following competitive tendering) for Formula Ford cars are:-

	Size	Specification Number
Front Tyre	6.0/21.0-13	7317
Rear Tyre	7.0/22.0-13	7319

As per normal the specification number will be moulded on one sidewall of the tyre. In addition each tyre will have a unique number moulded into the same sidewall as the specification number prefixed by an 'A' for tyres sold in the UK and an 'X' for tyres sold outside the UK (i.e. Europe)

No mechanical (other than rubber removal by normal wear), heat or chemical treatments are permitted to the "as sold" tyres (See also sporting regulations 1.11.1)

Supplied by
Avon Racing Division.
Cooper - Avon Tyres Ltd
Bath Road
Melksham
Wiltshire SN12 8AA
U. K.
Tel: 0044 (0)1225 703101
Fax: 0044 (0)1225 707443

Enquiries:

Sales	Technical
Brian Davis	Paul Coates

See sporting regulations for the number of tyres that can be used at any race meeting.

APPENDIX "D"

For Information only

Indicated below are Part Numbers for some of the more commonly used spare parts for the "Kent" engine. Part numbers starting with 909 can be purchased through Ford Dealers' or equivalent specialist dealers.

Finis Code	Description
9090001	Engine Assembly
9090125	Top Service Kit
9090956	Valve spring
9095317	Silencer (late)
9093539	Cylinder Block, Bare.
9096466	Piston Assembly, Grade 4D
9096467	Piston Assembly, Grade 3C
9094897	Crankshaft (Pt No. 711M 6303 AE)
9094722	Connecting Rod
1572456	Camshaft
1553961	Inlet Manifold
6009548	Short Motor Assembly.
1596693	Inlet Valve
6077327	Exhaust Valve
1428629	Clutch Disc
1420697	Clutch Cover
1471112	Cylinder Head 1.6 GT
1471113	Cylinder Head 1.6

History

Issue July 2001

Opening page Contacts revised.

Art 5.4b The number of the older silencer added. (Even though this unit is now out of stock)

Art 5.7 Part number of current Ford cylinder head gasket added.

Art 5.8 Recommended definition of camshaft altered to Ford profile, (was Ford ground component) as no Ford camshafts to this specification have been manufactured for over 10 years. (see below)

Appendix 'A'

Q3.1.5 Fire Extinguishers. Extinguishants not currently allowed in the UK are crossed out.

Appendix 'C'

Address and contact list for Avon corrected.

Parts list

Old silencer removed as no stocks exist. (9094277)

Flywheel deleted as no longer available (6032187)

Crankshaft part number updated to 9094897

Connecting rod part number updated to 9094722

Recommended changes

Owing to the unavailability of entirely produced Ford Motor Company camshafts, we strongly recommend that Art 5.8 be modified as below:-

- 5.8 CAMSHAFT
- The only permitted cam profile is that for the Ford 1600 GT "Kent" engine production camshaft.
 - The camshaft profile must remain entirely as originally intended for the Ford 1600 GT "Kent" engine, and cannot be modified. Tuffriding or Parkerising is permitted. Shot peening, shot blasting or polishing are prohibited. Offset dowels are permitted.
 - The cam profile is defined by determination of lift (L-l) against a flat footed follower at various angles (\emptyset). Maximum lift at all points on the camshaft must not be exceeded.

Issue Dec 2002

- 5.8 Current Camshaft Pt.No. 771M 6250 BA

For Information

Part Numbers for Ford specification parts that conform to these regulations are available from Formula Ford International under the following modified part numbers.

Camshaft	91572456
Inlet manifold	9094948
Inlet Valve	91596693
Exhaust Valve	96077327
Clutch Disc	2257100
Cylinder Head, 1.6 GT	9094928

Also most other parts shown in main parts list.

Issue January 2004

Art 5.14 The freedom granted to the water pump in this Article does not permit the substitution of another pump, in a different location and/or driven by a separate motor. The water pump must be driven directly from the Formula Ford 1600 engine. This is a decision of the Ford Motor Company Ltd. and concurred by the Motor Sports Association Ltd.

Issue March 2004

Page 2 Ford contact address changed N.B. Any new chassis built (whether it is a copy of an old design or not), must conform to the current Formula Ford 1800 safety requirements. This includes suspension anti intrusion bars (properly secured).

Only original equipment nose cones may be fitted. These cannot be filled with foam to increase stiffness.

Cars originally built as Formula Ford 1800 cars, but now converted to 1600 specification must retain all current 1800 safety requirements.